

SentryPanel PS1

Rev: 4.1

Issue Date: 26/05/2026

DATE: 05/06/2026
JOB REF: 25072061-04
REVISION: E
CHECKED & APPROVED BY BREVITY
LTD.
MATT BISHOP, CMENGNZ, CPENG
#243276

Brevity

Application

Engineering specifications & installation details for compliance with **NZBC B1, F4 & F9**

Barrier specification selection guide

Clause F4 'Safety from Falling' of the New Zealand Building Code requires building areas to be constructed to reduce the likelihood of accidental falls. Specifically, barriers are required where people could fall one metre or more.

Barriers need to be designed and constructed so that they are capable of providing the strength and stiffness necessary for the proposed location and occupancy type of the property which they serve. Evidence of the suitability of the barrier system for its proposed use, needs to be provided when making a

building consent application. This producer statement provides the assurance that Boundaryline product specifications and installation details have been pre-approved by Chartered Professional Engineers and comply with all NZBC B1, F4, F9 requirements.

It is important that your selected barrier design is appropriate to the specific installation location and intended use. Use this guide to determine your specific barrier design and installation details.

Generic Producer Statement

This is a generic Producer Statement, issued to Boundaryline Ltd, which provides the assurance that the proprietary products detailed in this document have been structurally engineered to comply with the New Zealand Building Code and the building code clauses as detailed, and for the application(s) as described in this document.

The fencing components detailed in this Producer Statement are proprietary products, engineered to comply with the requirements of the stated building code clause. Of equal importance is the detail of the fixing method to ensure the correct installation of the proprietary components. To this end, most common installation applications have been illustrated with appropriate details to ensure a safe and compliant fence/balustrade.

The structure (or ground conditions) to which the proprietary components are installed is the responsibility of the installer or end user, and it is recommended that an independent

engineer is engaged to confirm the compliance of the structure (or ground condition) with the New Zealand Building Code. Where relevant, and when critical to the compliance of the proprietary components, this producer statement details specific requirements of the structure (or ground conditions) as a minimum standard.

It is the installer or end user's responsibility to ensure the proprietary components are installed accurately to the detail provided. If your particular structure design or application is not covered in the details provided, then this generic producer statement cannot be applied to your installation. In this instance, please contact Boundaryline to discuss a custom-engineered solution that will meet your requirements.

How to use this document

This producer statement includes details for a variety of designs and applications, to ensure you get the right panel and fixing details for your application, please follow the instructions below:

- Step 1.** Check the Design Loading that applies to your application, (see Table 1). There are different design loadings and minimum barrier heights that apply to various occupancy types and scenarios.
- Step 2.** Using Table 2, you will be able to see what Panel styles are able to be used with the Loading identified in Step 1. This will also give you the Maximum post centre you can install this panel at and will direct you to the Panel Drawing page.
- Step 3.** On the applicable Panel drawing, take note of how the panel is installed and what posts you can use, then follow the drawing numbers to see the approved post fixing details for the applicable Loading and Panel Style.
- Step 4.** In these pages you will find the fixing drawings that we have designed for most common applications, if the application that you are needing isn't shown here, please let us know and we can find a custom solution for you.

DATE: 05/06/2026 JOB REF: 25072061-04 REVISION: E CHECKED & APPROVED BY BREVITY LTD. MATT BISHOP, CMENGNZ, CPENG #243276	Brevity
---	----------------

Barrier Loading Selection

Where a barrier serves multiple occupancies, default to the highest loading requirement from all location scenarios. For more information, please refer to www.buildin.govt.nz

Occupancy type	Building code clause	Specific use	Horizontal design loading	Minimum overall barrier height
A - Domestic	F9	Pool fence only	0.33kN	1.2m
A - Domestic	F4	All areas serving one dwelling but excluding balconies, decks & terraces, e.g., walkways, stairs & landings, & retaining walls not adjacent to a deck or terrace	0.35kN/m	1.0m 0.9m for stairs only
A - Domestic	F4	External balcony, decks, terraces, retaining walls & walkways in a multi-dwelling application, including open public spaces	0.75kN/m	1.0m single dwelling 1.1m multi dwelling
B & E - Offices & work areas including storage	F4	Access walkways, stairs & landings	0.35kN/m	1.1m
B & E - Offices & work areas including storage	F4	Areas including balconies, decks & terraces not susceptible to overcrowding	0.75kN/m	1.1m
C - Areas without obstacles for moving people & where people might congregate	F4	Areas including walkways, stairs & landings, balconies, decks & terraces not susceptible to overcrowding, including parks and reserves	0.75kN/m	1.1m

Table 1 - Barrier Loading Selection

Fixing types

There are four corrosion zones in New Zealand that relate to the severity of exposure to wind-driven salt. To determine the corrosion zone for your installation location, please check maps in Figure 4.2 in NZS3604:201 (or online search 'BRANZ Maps'). Use the table below to determine the appropriate fixing types required for your particular location.

Zone	Risk level & location	Fixing type
Zone B	Low risk	Hot dip galvinised
Zone C	Medium risk	Hot dip galvinised
Zone D	High risk, all offshore locations within 500m of coastline, including harbours, locations within 100m of tidal estuaries & sheltered inlets	316 stainless steel
Zone E	Very high risk, locations described in Zone D, beachfronts & seaside locations	316 stainless steel

Table 2 - Fixing Types

DATE: 05/06/2026
 JOB REF: 25072061-04
 REVISION: E
 CHECKED & APPROVED BY BREVITY LTD.
 MATT BISHOP, CMENGNZ, CPENG
 #243276



Barrier Panel Selection





SentryPanel	Height	Code	Maximum Post Centre			Page
			F9 Pool Fencing	F4 – 0.35kN/m	F4 – 0.75kN/m	
 School Panel	1500mm	SAE1522-BK	2320mm*	1195mm	1195mm	5
	1800mm	SAE1822-BK	2320mm**	1195mm	1195mm	5
 School Panel Raking	1500mm	SER1524-BK	N/A	1195mm	1195mm	5
	1800mm	SER1824-BK	N/A	1195mm	1195mm	5
 Flat Top	1500mm	SAF1522-BK	2320mm*	1195mm	1195mm	6
	1800mm	SAF1822-BK	2320mm*	1195mm	1195mm	6
 Flat Top Raking	1500mm	SFR1524-BK	N/A	1195mm	1195mm	6
	1800mm	SFR1824-BK	N/A	1195mm	1195mm	6
 Playground Panel	950mm	SPR9524-BK	N/A	1250mm	1250mm	7
	1200mm	SPR1224-BK	2470mm*	1250mm	1250mm	7
	1500mm	SPR1524-BK	2470mm*	1250mm	1250mm	7
	1800mm	SPR1824-BK	2470mm*	1250mm	1250mm	7

Table 3 - Barrier Panel Selection

*See Page 7 for typical pool fence installation and requirements.

**Although this is a 1800h Panel it doesn't comply when installed as a pool barrier on a property boundary. Refer to note 2.2.1 d) of Building Code Acceptable Solutions F9/AS1 and F9/AS2 document.

For pool fencing: In case of extreme wind events, the fences will need to be inspected to ensure F9 – “restricting access to residential pools” compliance. Damaged fence components must be replaced before the fence can be safely utilized. Studio89 and Boundaryline assumes no liability from extreme wind events.

DATE: 05/06/2026
 JOB REF: 25072061-04
 REVISION: E
 CHECKED & APPROVED BY BREVITY LTD.
 MATT BISHOP, CMENGNZ, CPENG
 #243276

Brevity

BOUNDARYLINE SENTRY PANEL SCHOOL PANEL FENCE FOR F9 (POOL FENCE) APPLICATIONS

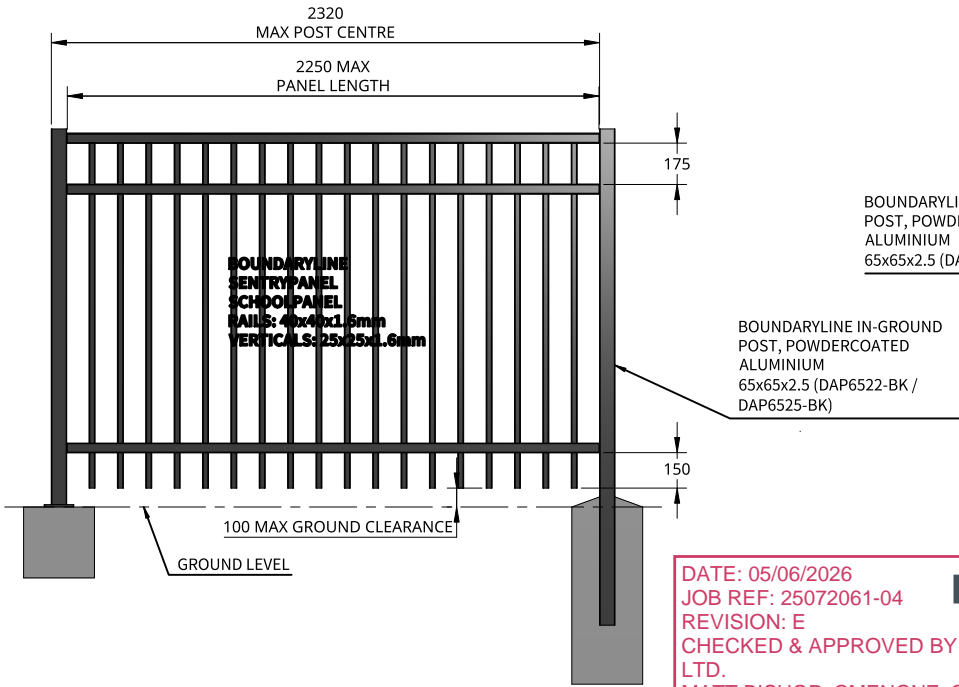

BOUNDARYLINE SENTRY PANEL SCHOOL PANEL FENCE FOR F4 - (FALL RESTRAINT BARRIER) APPLICATIONS

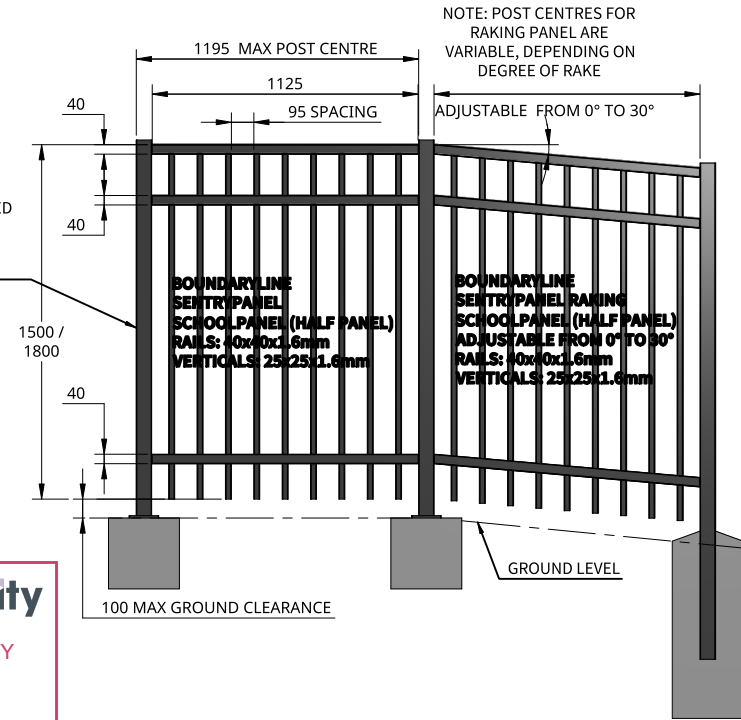

DATE: 05/06/2026
 JOB REF: 25072061-04
 REVISION: E
 CHECKED & APPROVED BY BREVITY LTD.
 MATT BISHOP, CMENGNZ, CPENG
 #243276



General Notes

1. All dimensions are in millimetres.
2. Drawings are not necessarily to scale
3. Check www.boundaryline.co.nz to ensure you have the most recent edition of this publication.

Fixing Notes

1. All coach screws and bolts to be pre-drilled according to NZS 3603:1997
2. When fixing self-drilling screws, ensure low torque setting to avoid thread stripping. A battery drill is recommended for self-drilling screws - DO NOT use an impact driver.

Corrosion Zones

There are four corrosion zones in New Zealand that relate to the severity of exposure to wind-driven salt. See maps in figure 4.2 of NZS 3604:2011 (or online search 'BRANZ Maps') to determine the corrosion zone of the installation location and appropriate fixing option required.

Zone	Risk Level & Location	Fixing Type
Zone B	Low risk	Hot-dip Galvanised
Zone C	Medium risk	Hot-dip Galvanised
Zone D	High risk, all offshore islands, locations within 500m of coastline including harbours, locations within 100m of tidal estuaries and sheltered inlets.	316 Stainless Steel
Zone E	Very high risk, locations described in Zone D, beachfronts and seaside locations.	316 Stainless Steel

Existing Support Structure

1. Supporting structures as not covered by these drawings unless specific requirements are detailed.
2. Supporting structures are by others and must comply with the New Zealand Building Code.
3. If unsure of existing structure compliance, seek professional advice.



Boundaryline Ltd.
 60 Bastian Street, Invercargill
 Phone: 0800 003 006
 Email: enquiries@boundaryline.co.nz
 Website: www.boundaryline.co.nz
 © Copyright June 2025. All rights reserved to Boundaryline Ltd.

This document and the copyright in this document remain the property of BOUNDARYLINE LTD. The contents of this document may not be reproduced either in whole or in part by any means whatsoever without the prior written consent of BOUNDARYLINE LTD.

TITLE		
BOUNDARYLINE SENTRY PANEL SCHOOL PANEL		

SCALE	SIZE	DRAWING NO
1:32	A4	SPS01
REV.	DATE ISSUED	SHEET
3	26/05/2026	5

Panel Type	1500 High - SAE1524-BK			1500 High Raking - SER1524-BK			1800 High - SAE1824-BK			1800 High Raking - SER1824-BK		
	F9 (Pool Fence)	F4 - 0.35kN/m (Fall Restraint)	F4 - 0.75kN/m (Fall Restraint)	F9 (Pool Fence)	F4 - 0.35kN/m (Fall Restraint)	F4 - 0.75kN/m (Fall Restraint)	F9 (Pool Fence)	F4 - 0.35kN/m (Fall Restraint)	F4 - 0.75kN/m (Fall Restraint)	F9 (Pool Fence)	F4 - 0.35kN/m (Fall Restraint)	F4 - 0.75kN/m (Fall Restraint)
Loadings	F9 (Pool Fence)	F4 - 0.35kN/m (Fall Restraint)	F4 - 0.75kN/m (Fall Restraint)	F9 (Pool Fence)	F4 - 0.35kN/m (Fall Restraint)	F4 - 0.75kN/m (Fall Restraint)	F9 (Pool Fence)	F4 - 0.35kN/m (Fall Restraint)	F4 - 0.75kN/m (Fall Restraint)	F9 (Pool Fence)	F4 - 0.35kN/m (Fall Restraint)	F4 - 0.75kN/m (Fall Restraint)
Max Post Centres (mm)	2320	1195	1195	N/A	1195	1195	2320	1195	1195	N/A	1195	1195
In-Ground Post Options	65x65x2.5 SHS DAP6522-BK / DAP6525-BK	65x65x2.5 SHS DAP6522-BK / DAP6525-BK	65x65x2.5 SHS DAP6522-BK / DAP6525-BK	N/A	65x65x2.5 SHS DAP6522-BK / DAP6525-BK	65x65x2.5 SHS DAP6522-BK / DAP6525-BK	65x65x2.5 SHS DAP6525-BK	65x65x2.5 SHS DAP6525-BK	65x65x2.5 SHS DAP6525-BK	N/A	65x65x2.5 SHS DAP6525-BK	65x65x2.5 SHS DAP6525-BK
Flanged Post Options	65x65x2.5 SHS DAF6519-BK	65x65x2.5 SHS DAF6519-BK	65x65x2.5 SHS DAF6519-BK	N/A	65x65x2.5 SHS DAF6519-BK	65x65x2.5 SHS DAF6519-BK	65x65x2.5 SHS DAF6519-BK	65x65x2.5 SHS DAF6519-BK	65x65x2.5 SHS DAF6519-BK	N/A	65x65x2.5 SHS DAF6519-BK	65x65x2.5 SHS DAF6519-BK
Applicable Fixing Details	SEA657501 SEA657502 SEA657503	SEA657501 SEA657502 SEA657503	SEA657501 SEA657502 SEA657503	N/A	SEA657501 SEA657502 SEA657503	SEA657501 SEA657502 SEA657503	SEA657501 SEA657502 SEA657503	SEA657501 SEA657502 SEA657503	SEA657501 SEA657502 SEA657503	N/A	SEA657501 SEA657502 SEA657503	SEA657501 SEA657502 SEA657503

IMPORTANT: THIS DESIGN AND ASSOCIATED DESIGN PRODUCER STATEMENTS ARE ONLY RELEVANT FOR PROPRIETARY BOUNDARYLINE PRODUCTS; ANY PRODUCT SUBSTITUTIONS WILL INVALIDATE THE PRODUCER STATEMENT

**BOUNDARYLINE SENTRY PANEL FLAT TOP PANEL
FENCE FOR F9 (POOL FENCE) APPLICATIONS**

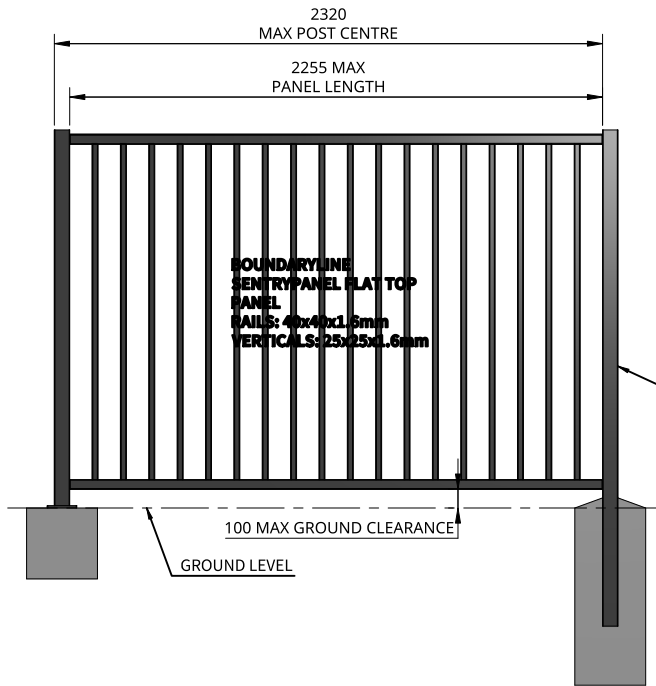

**BOUNDARYLINE SENTRY PANEL FLAT TOP PANEL
FENCE FOR F4 - (FALL RESTRAINT BARRIER)
APPLICATIONS**

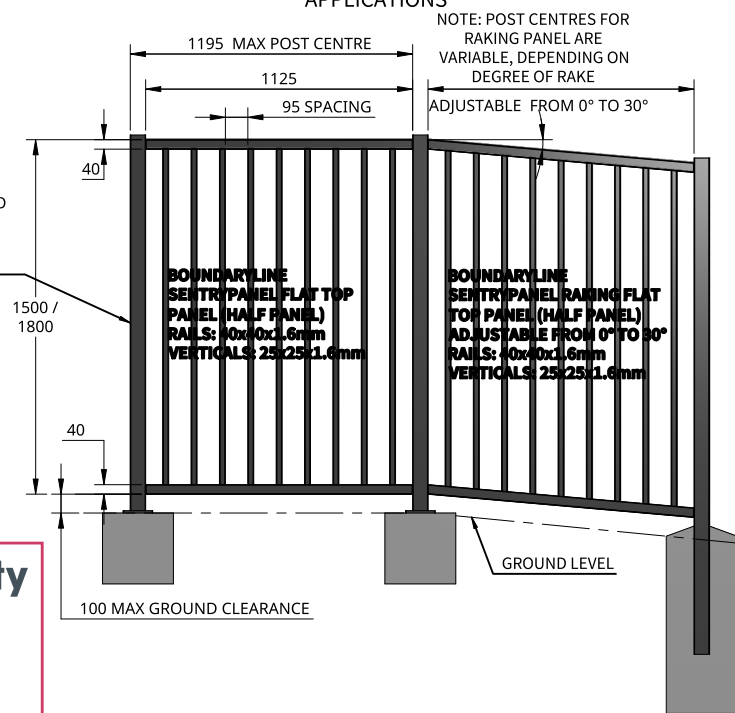

DATE: 05/06/2026
JOB REF: 25072061-04
REVISION: E
CHECKED & APPROVED BY BREVITY LTD.
MATT BISHOP, CMENGNZ, CPENG
#243276

Brevity

General Notes

1. All dimensions are in millimetres.
2. Drawings are not necessarily to scale
3. Check www.boundaryline.co.nz to ensure you have the most recent edition of this publication.

Fixing Notes

1. All coach screws and bolts to be pre-drilled according to NZS 3603:1997
2. When fixing self-drilling screws, ensure low torque setting to avoid thread stripping. A battery drill is recommended for self-drilling screws - DO NOT use an impact driver.

Corrosion Zones

There are four corrosion zones in New Zealand that relate to the severity of exposure to wind-driven salt. See maps in figure 4.2 of NZS 3604:2011 (or online search 'BRAINZ Maps') to determine the corrosion zone of the installation location and appropriate fixing option required.

Zone	Risk Level & Location	Fixing Type
Zone B	Low risk	Hot-dip Galvanised
Zone C	Medium risk	Hot-dip Galvanised
Zone D	High risk, all offshore islands, locations within 500m of coastline including harbours, locations within 100m of tidal estuaries and sheltered inlets.	316 Stainless Steel
Zone E	Very high risk, locations described in Zone D, beachfronts and seaside locations.	316 Stainless Steel

Existing Support Structure

1. Supporting structures as not covered by these drawings unless specific requirements are detailed.
2. Supporting structures are by others and must comply with the New Zealand Building Code.
3. If unsure of existing structure compliance, seek professional advice.



Boundaryline Ltd.
60 Basstian Street, Invercargill
Phone: 0800 003 006
Email: enquiries@boundaryline.co.nz
Website: www.boundaryline.co.nz
© Copyright June 2025. All rights reserved to Boundaryline Ltd.

This document and the copyright in this document remain the property of BOUNDARYLINE LTD. The contents of this document may not be reproduced either in whole or in part by any means whatsoever without the prior written consent of BOUNDARYLINE LTD.

TITTLE		
BOUNDARYLINE SENTRY PANEL FLAT TOP PANEL		

SCALE	SIZE	DRAWING NO
1:32	A4	SPF01
REV.	DATE ISSUED	SHEET
3	26/05/2026	6

Panel Type	1500 High - SAF1524-BK			1500 High Raking - SFR1524-BK			1800 High - SAF1824-BK			1800 High Raking - SFR1824-BK		
	F9 (Pool Fence)	F4 - 0.35kN/m (Fall Restraint)	F4 - 0.75kN/m (Fall Restraint)	F9 (Pool Fence)	F4 - 0.35kN/m (Fall Restraint)	F4 - 0.75kN/m (Fall Restraint)	F9 (Pool Fence)	F4 - 0.35kN/m (Fall Restraint)	F4 - 0.75kN/m (Fall Restraint)	F9 (Pool Fence)	F4 - 0.35kN/m (Fall Restraint)	F4 - 0.75kN/m (Fall Restraint)
Loadings	F9 (Pool Fence)	F4 - 0.35kN/m (Fall Restraint)	F4 - 0.75kN/m (Fall Restraint)	F9 (Pool Fence)	F4 - 0.35kN/m (Fall Restraint)	F4 - 0.75kN/m (Fall Restraint)	F9 (Pool Fence)	F4 - 0.35kN/m (Fall Restraint)	F4 - 0.75kN/m (Fall Restraint)	F9 (Pool Fence)	F4 - 0.35kN/m (Fall Restraint)	F4 - 0.75kN/m (Fall Restraint)
Max Post Centres (mm)	2320	1195	1195	N/A	1195	1195	2320	1195	1195	N/A	1195	1195
In-Ground Post Options	65x65x2.5 SHS DAP6522-BK / DAP6525-BK	65x65x2.5 SHS DAP6522-BK / DAP6525-BK	65x65x2.5 SHS DAP6522-BK / DAP6525-BK	N/A	65x65x2.5 SHS DAP6522-BK / DAP6525-BK	65x65x2.5 SHS DAP6522-BK / DAP6525-BK	65x65x2.5 SHS DAP6525-BK	65x65x2.5 SHS DAP6525-BK	65x65x2.5 SHS DAP6525-BK	N/A	65x65x2.5 SHS DAP6525-BK	65x65x2.5 SHS DAP6525-BK
Flanged Post Options	65x65x2.5 SHS DAF6519-BK	65x65x2.5 SHS DAF6519-BK	65x65x2.5 SHS DAF6519-BK	N/A	65x65x2.5 SHS DAF6519-BK	65x65x2.5 SHS DAF6519-BK	65x65x2.5 SHS DAF6519-BK	65x65x2.5 SHS DAF6519-BK	65x65x2.5 SHS DAF6519-BK	N/A	65x65x2.5 SHS DAF6519-BK	65x65x2.5 SHS DAF6519-BK
Applicable Fixing Details	SEA657501 SEA657502 SEA657503	SEA657501 SEA657502 SEA657503	SEA657501 SEA657502 SEA657503	N/A	SEA657501 SEA657502 SEA657503	SEA657501 SEA657502 SEA657503	SEA657501 SEA657502 SEA657503	SEA657501 SEA657502 SEA657503	SEA657501 SEA657502 SEA657503	N/A	SEA657501 SEA657502 SEA657503	SEA657501 SEA657502 SEA657503

IMPORTANT: THIS DESIGN AND ASSOCIATED DESIGN PRODUCER STATEMENTS ARE ONLY RELEVANT FOR PROPRIETARY BOUNDARYLINE PRODUCTS; ANY PRODUCT SUBSTITUTIONS WILL INVALIDATE THE PRODUCER STATEMENT

**BOUNDARYLINE SENTRY PANEL PLAYGROUND
PANEL FENCE FOR F9 (POOL FENCE)
APPLICATIONS**

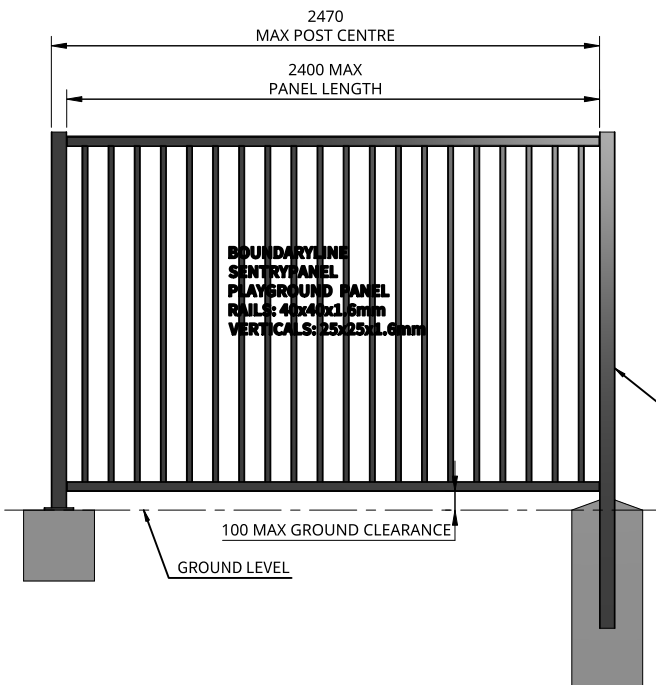

**BOUNDARYLINE SENTRY PANEL PLAYGROUND PANEL
FENCE FOR F4 - (FALL RESTRAINT BARRIER)
APPLICATIONS**

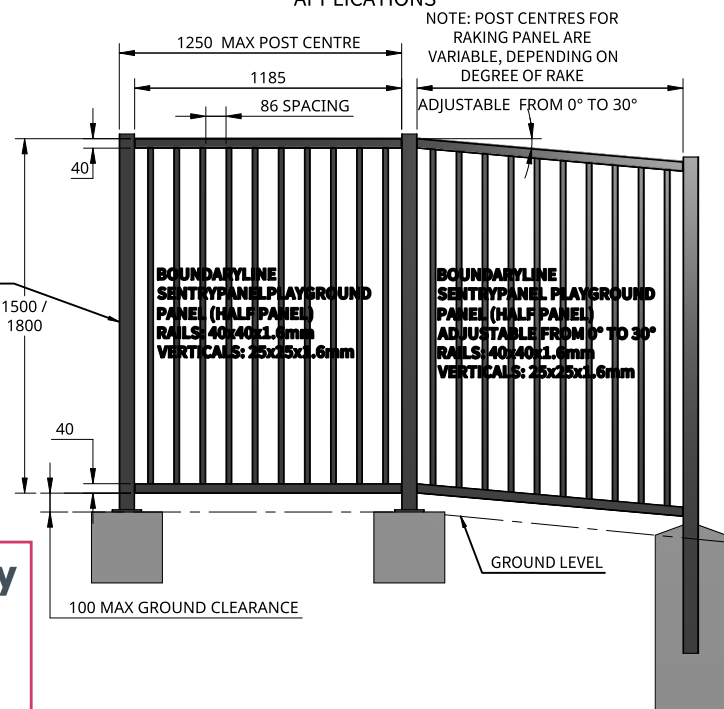

DATE: 05/06/2026
JOB REF: 25072061-04
REVISION: E
CHECKED & APPROVED BY BREVITY LTD.
MATT BISHOP, CMENGNZ, CPENG
#243276



General Notes

- All dimensions are in millimetres.
- Drawings are not necessarily to scale
- Check www.boundaryline.co.nz to ensure you have the most recent edition of this publication.

Fixing Notes

- All coach screws and bolts to be pre-drilled according to NZS 3603:1997
- When fixing self-drilling screws, ensure low torque setting to avoid thread stripping. A battery drill is recommended for self-drilling screws - DO NOT use an impact driver.

Corrosion Zones

There are four corrosion zones in New Zealand that relate to the severity of exposure to wind-driven salt. See maps in figure 4.2 of NZS 3604:2011 (or online search '*BRA NZ Maps*') to determine the corrosion zone of the installation location and appropriate fixing option required.

Zone	Risk Level & Location	Fixing Type
Zone B	Low risk	Hot-dip Galvanised
Zone C	Medium risk	Hot-dip Galvanised
Zone D	High risk, all offshore islands, locations within 500m of coastline including harbours, locations within 100m of tidal estuaries and sheltered inlets.	316 Stainless Steel
Zone E	Very high risk, locations described in Zone D, beachfronts and seaside locations.	316 Stainless Steel

Existing Support Structure

- Supporting structures as not covered by these drawings unless specific requirements are detailed.
- Supporting structures are by others and must comply with the New Zealand Building Code.
- If unsure of existing structure compliance, seek professional advice.



Boundaryline Ltd.
60 Basstian Street, Invercargill
Phone: 0800 003 006
Email: enquiries@boundaryline.co.nz
Website: www.boundaryline.co.nz
© Copyright June 2025. All rights reserved to Boundaryline Ltd.

This document and the copyright in this document remain the property of BOUNDARYLINE LTD. The contents of this document may not be reproduced either in whole or in part by any means whatsoever without the prior written consent of BOUNDARYLINE LTD.

TITLE		
BOUNDARYLINE SENTRY PANEL PLAYGROUND PANEL		

SCALE	SIZE	DRAWING NO
1:32	A4	SPP01
REV.	DATE ISSUED	SHEET
3	26/05/2026	7

Panel Type	950 High Raking - SPR9524-BK			1200 High Raking - SPR1224-BK			1500 High Raking - SPR1524-BK			1800 High Raking - SPR1824-BK		
	F9 (Pool Fence)	F4 - 0.35kN/m (Fall Restraint)	F4 - 0.75kN/m (Fall Restraint)	F9 (Pool Fence)	F4 - 0.35kN/m (Fall Restraint)	F4 - 0.75kN/m (Fall Restraint)	F9 (Pool Fence)	F4 - 0.35kN/m (Fall Restraint)	F4 - 0.75kN/m (Fall Restraint)	F9 (Pool Fence)	F4 - 0.35kN/m (Fall Restraint)	F4 - 0.75kN/m (Fall Restraint)
Loadings	N/A											
Max Post Centres (mm)	N/A	1250	1250	2470	1250	1250	2470	1250	1250	2470	1250	1250
In-Ground Post Options	N/A	65x65x2.5 SHS DAP6519-BK	65x65x2.5 SHS DAP6519-BK	65x65x2.5 SHS DAP6519-BK	65x65x2.5 SHS DAP6519-BK	65x65x2.5 SHS DAP6519-BK	65x65x2.5 SHS DAP6522-BK	65x65x2.5 SHS DAP6525-BK	65x65x2.5 SHS DAP6525-BK	65x65x2.5 SHS DAP6525-BK	65x65x2.5 SHS DAP6525-BK	65x65x2.5 SHS DAP6525-BK
Flanged Post Options	N/A	65x65x2.5 SHS DAF6513-BK	65x65x2.5 SHS DAF6513-BK	65x65x2.5 SHS DAF6513-BK	65x65x2.5 SHS DAF6513-BK	65x65x2.5 SHS DAF6513-BK	65x65x2.5 SHS DAF6519-BK	65x65x2.5 SHS DAF6519-BK	65x65x2.5 SHS DAF6519-BK	65x65x2.5 SHS DAF6519-BK	65x65x2.5 SHS DAF6519-BK	65x65x2.5 SHS DAF6519-BK
Applicable Fixing Details	N/A	SEA657501 SEA657502 SEA657503	SEA657501 SEA657502 SEA657503	SEA657501 SEA657502 SEA657503	SEA657501 SEA657502 SEA657503	SEA657501 SEA657502 SEA657503	SEA657501 SEA657502 SEA657503	SEA657501 SEA657502 SEA657503	SEA657501 SEA657502 SEA657503	SEA657501 SEA657502 SEA657503	SEA657501 SEA657502 SEA657503	SEA657501 SEA657502 SEA657503

IMPORTANT: THIS DESIGN AND ASSOCIATED DESIGN PRODUCER STATEMENTS ARE ONLY RELEVANT FOR PROPRIETARY BOUNDARYLINE PRODUCTS; ANY PRODUCT SUBSTITUTIONS WILL INVALIDATE THE PRODUCER STATEMENT

BOUNDARYLINE SENTRY PANEL FENCE FOR F9
(POOL FENCE) APPLICATIONS

DATE: 05/06/2026
JOB REF: 25072061-04
REVISION: E
CHECKED & APPROVED BY BREVITY LTD.
MATT BISHOP, CMENGNZ, CPENG
#243276

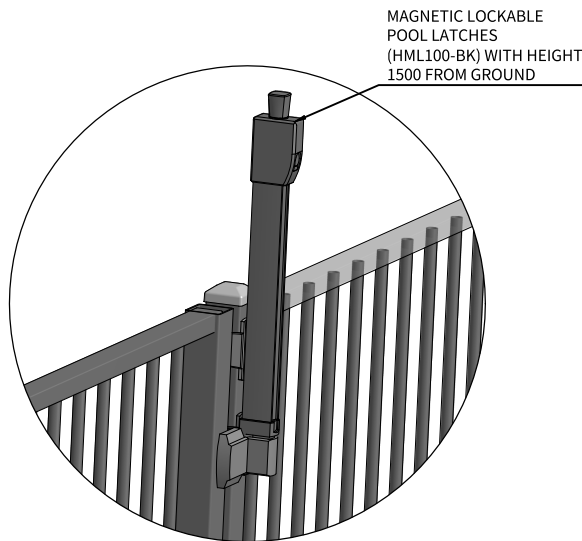
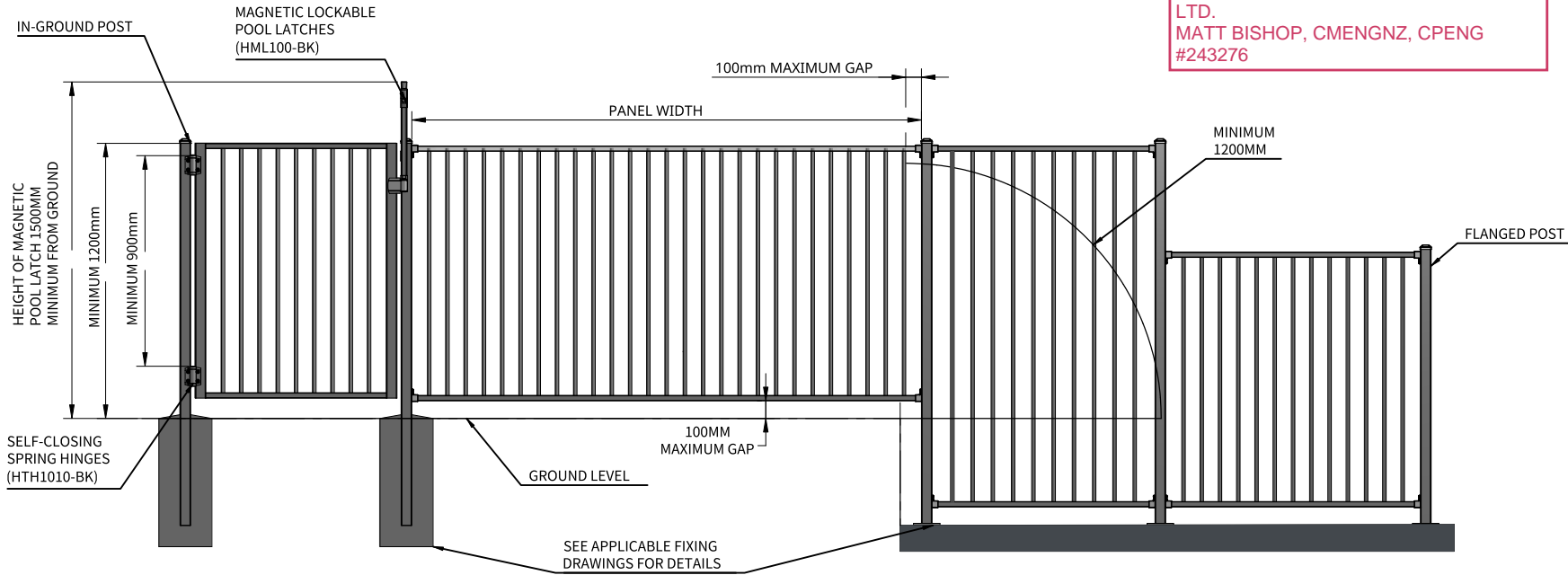

MAGNETIC LOCKABLE LATCHES (HML100-BK)
1:10

General Notes

- All dimensions are in millimetres.
- Drawings are not necessarily to scale
- Check www.boundaryline.co.nz to ensure you have the most recent edition of this publication.

Fixing Notes

- All coach screws and bolts to be pre-drilled according to NZS 3603:1997
- When fixing self-drilling screws, ensure low torque setting to avoid thread stripping. A battery drill is recommended for self-drilling screws - DO NOT use an impact driver.

Corrosion Zones

There are four corrosion zones in New Zealand that relate to the severity of exposure to wind-driven salt. See maps in figure 4.2 of NZS 3604:2011 (or online search 'BRANZ Maps') to determine the corrosion zone of the installation location and appropriate fixing option required.

Zone	Risk Level & Location	Fixing Type
Zone B	Low risk	Hot-dip Galvanised
Zone C	Medium risk	Hot-dip Galvanised
Zone D	High risk, all offshore islands, locations within 500m of coastline including harbours, locations within 100m of tidal estuaries and sheltered inlets.	316 Stainless Steel
Zone E	Very high risk, locations described in Zone D, beachfronts and seaside locations.	316 Stainless Steel

Existing Support Structure

- Supporting structures as not covered by these drawings unless specific requirements are detailed.
- Supporting structures are by others and must comply with the New Zealand Building Code.
- If unsure of existing structure compliance, seek professional advice.



Boundaryline Ltd.
60 Basstian Street, Invercargill
Phone: 0800 003 006
Email: enquiries@boundaryline.co.nz
Website: www.boundaryline.co.nz
© Copyright June 2025. All rights reserved to Boundaryline Ltd.

This document and the copyright in this document remain the property of BOUNDARYLINE LTD. The contents of this document may not be reproduced either in whole or in part by any means whatsoever without the prior written consent of BOUNDARYLINE LTD.

TITLE		
BOUNDARYLINE SENTRY PANEL TYPICAL POOL FENCE INSTALL		

SCALE	SIZE	DRAWING NO
1:32	A4	PFI01
REV.	DATE ISSUED	SHEET
A	26/05/2026	8

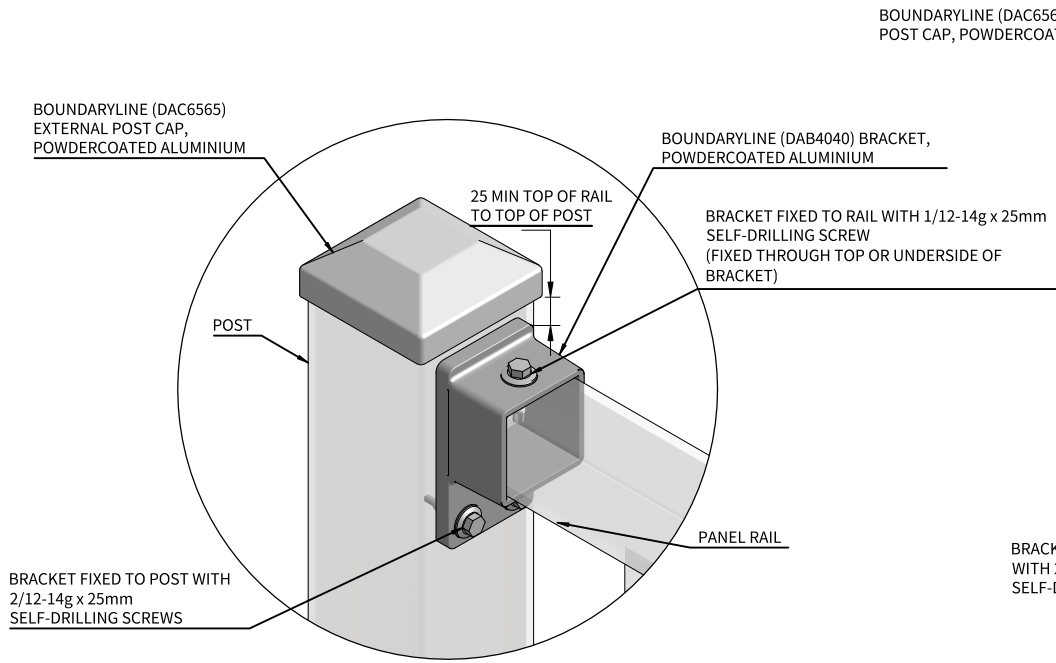

STANDARD PANEL BRACKET FIXING DETAIL
1:3

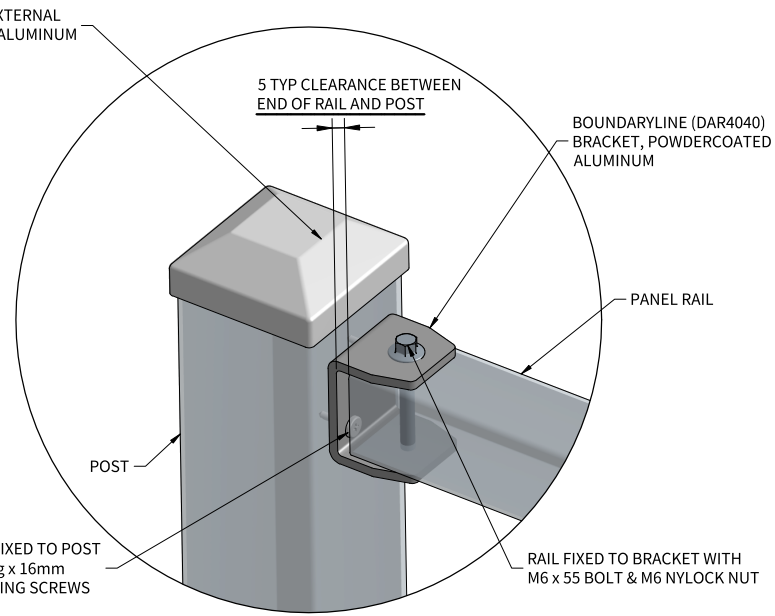

DIRECTIONAL PANEL BRACKET FIXING DETAIL
1:3

NOTE:
WHEN FIXING SCREWS USE LOW TORQUE SETTING ON DRILL TO ENSURE THREAD IS NOT STRIPPED. USE EXTRA CAUTION WHEN FIXING INTO ALUMINIUM. DO NOT USE AN IMPACT DRIVER AS THIS WILL VOID BOUNDARYLINE WARRANTY

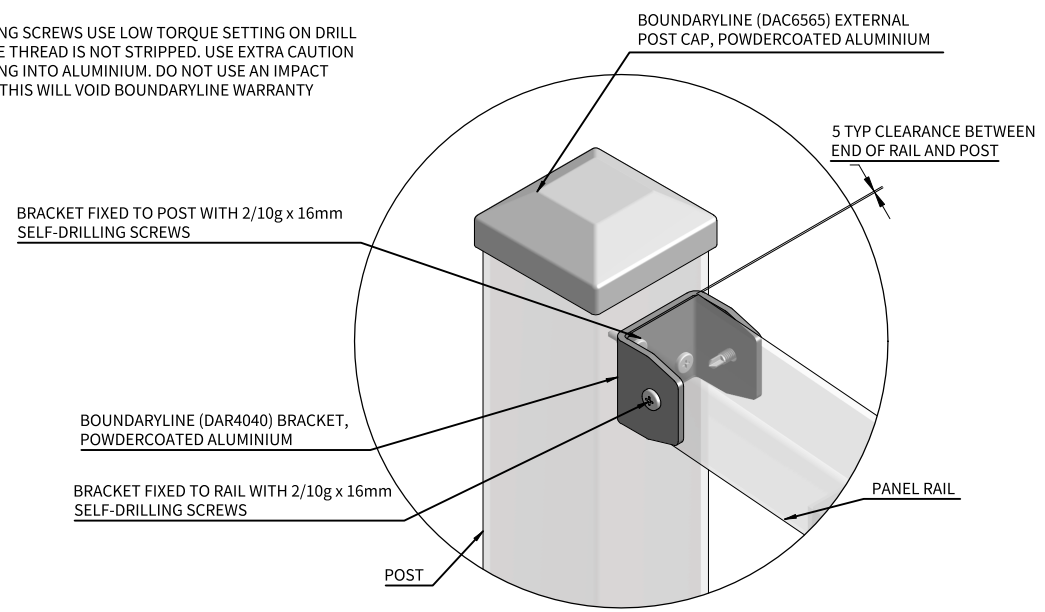

RAKING PANEL BRACKET FIXING DETAIL
1:3

DATE: 05/06/2026
JOB REF: 25072061-04
REVISION: E
CHECKED & APPROVED BY BREVITY LTD.
MATT BISHOP, CMENGNZ, CPENG
#243276

Brevity

General Notes
1. All dimensions are in millimetres.
2. Drawings are not necessarily to scale
3. Check www.boundaryline.co.nz to ensure you have the most recent edition of this publication.

Fixing Notes
1. All coach screws and bolts to be pre-drilled according to NZS 3603:1997
2. When fixing self-drilling screws, ensure low torque setting to avoid thread stripping. A battery drill is recommended for self-drilling screws - DO NOT use an impact driver.

Corrosion Zones
There are four corrosion zones in New Zealand that relate to the severity of exposure to wind-driven salt. See maps in figure 4.2 of NZS 3604:2011 (or online search 'BRANZ Maps') to determine the corrosion zone of the installation location and appropriate fixing option required.

Zone	Risk Level & Location	Fixing Type
Zone B	Low risk	Hot-dip Galvanised
Zone C	Medium risk	Hot-dip Galvanised
Zone D	High risk, all offshore islands, locations within 500m of coastline including harbours, locations within 100m of tidal estuaries and sheltered inlets.	316 Stainless Steel
Zone E	Very high risk, locations described in Zone D, beachfronts and seaside locations.	316 Stainless Steel

Existing Support Structure
1. Supporting structures as not covered by these drawings unless specific requirements are detailed.
2. Supporting structures are by others and must comply with the New Zealand Building Code.
3. If unsure of existing structure compliance, seek professional advice.

Boundaryline
Boundaryline Ltd.
60 Bastian Street, Invercargill
Phone: 0800 003 006
Email: enquiries@boundaryline.co.nz
Website: www.boundaryline.co.nz
© Copyright June 2025. All rights reserved to Boundaryline Ltd.

This document and the copyright in this document remain the property of BOUNDARYLINE LTD. The contents of this document may not be reproduced either in whole or in part by any means whatsoever without the prior written consent of BOUNDARYLINE LTD.

TITLE
**BOUNDARYLINE
SENTRY PANEL RAIL
BRACKET DETAILS**

SCALE	SIZE	DRAWING NO
1:25	A4	SPB01
REV.	DATE ISSUED	SHEET
3	26/05/2026	9

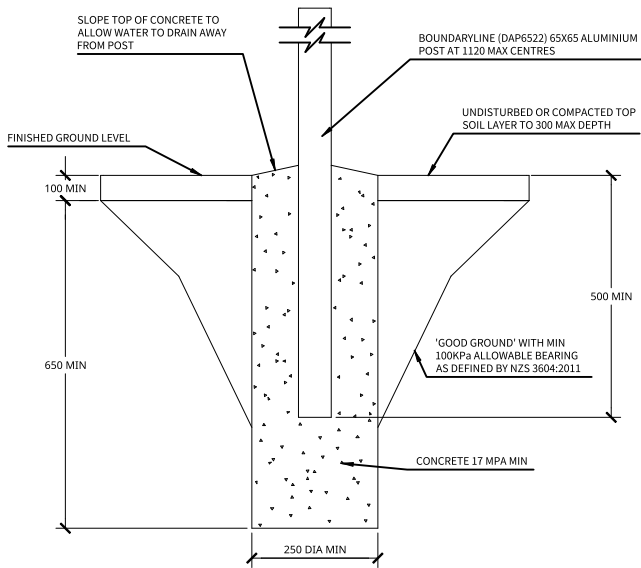

DRAWING NO: ICA657512
 APPLICATION: CONCRETE IN-GROUND
 LOADING: 0.33kN [F9] AT MAX 2320 POST CENTRES
 LOADING: 0.35kN/m AT MAX 1195 POST CENTRES
 LOADING: 0.75kN/m AT MAX 1195 POST CENTRES
 HEIGHTS: 1500, 1800

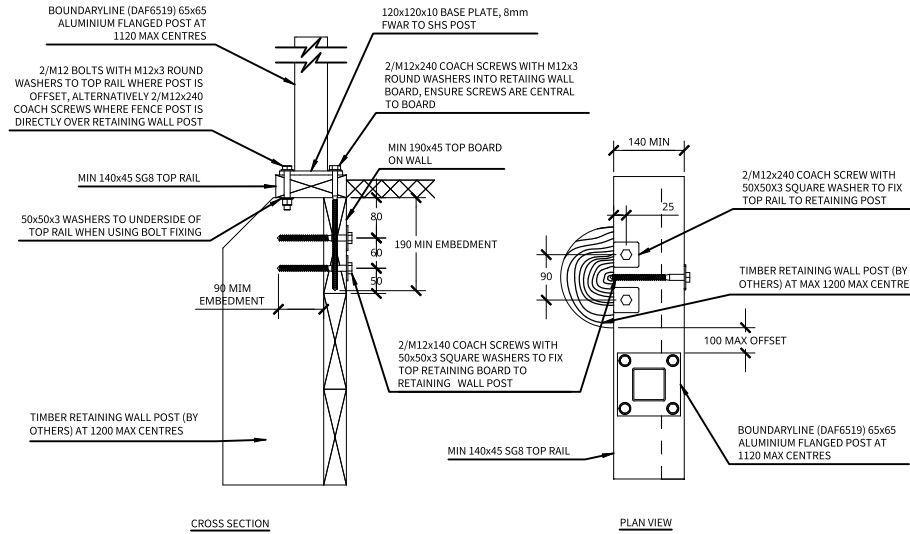

DRAWING NO: TRA657512
 APPLICATION: TOP-FIX TO TIMBER RETAINING WALL
 LOADING: 0.33kN [F9] AT MAX 2320 POST CENTRES
 LOADING: 0.35kN/m AT MAX 1195 POST CENTRES
 LOADING: 0.75kN/m AT MAX 1195 POST CENTRES
 HEIGHTS: 1500, 1800

DATE: 05/06/2026
 JOB REF: 25072061-04
 REVISION: E
 CHECKED & APPROVED BY BREVITY LTD.
 MATT BISHOP, CMENGNZ, CPENG
 #243276

Brevity

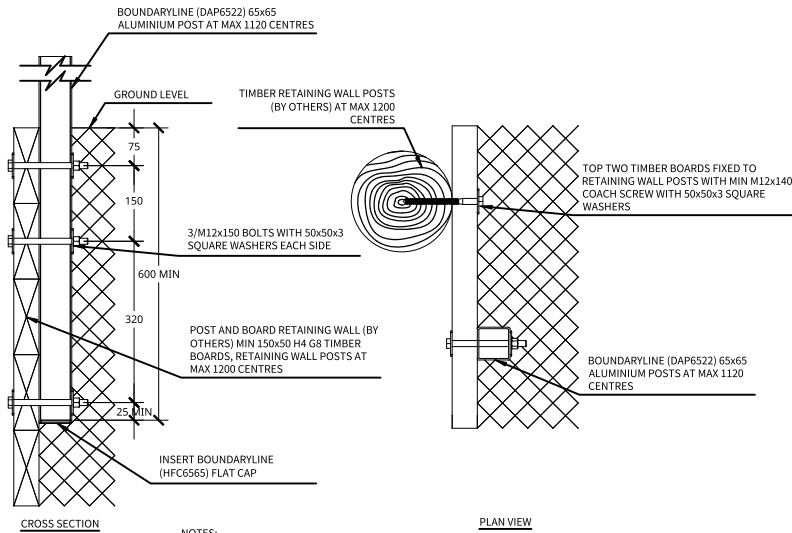

NOTES:
 IF WALL IS SLOPING, PACK FENCE POSTS TO VERTICAL AND ADJUST BOLT LENGTH TO SUIT.
 ALL IN-GROUND FIXINGS TO BE STAINLESS STEEL OR GALVANISED WITH DPM PROTECTION

DRAWING NO: SRA657512-A
 APPLICATION: SIDE-FIX TO TIMBER RETAINING WALL (POST ON INSIDE OF RETAINING WALL)
 LOADING: 0.33kN [F9] AT MAX 2320 POST CENTRES
 LOADING: 0.35kN/m AT MAX 1195 POST CENTRES
 LOADING: 0.75kN/m AT MAX 1195 POST CENTRES
 HEIGHTS: 1500, 1800

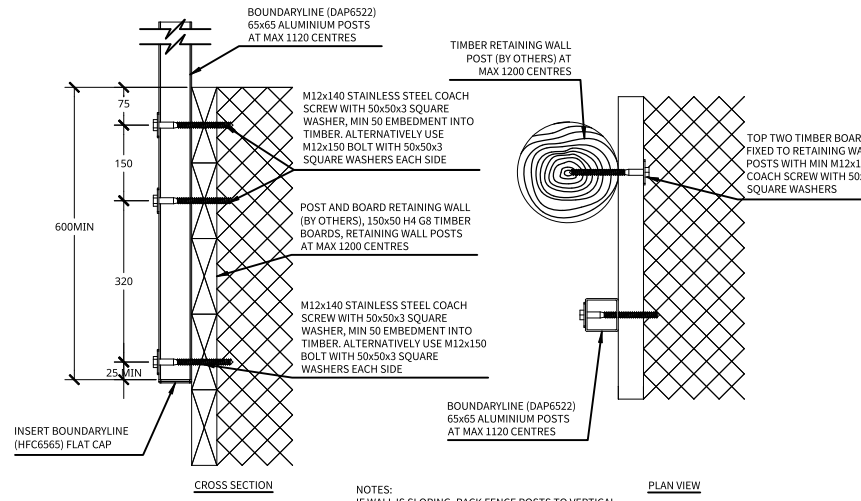

NOTES:
 IF WALL IS SLOPING, PACK FENCE POSTS TO VERTICAL AND ADJUST COACH SCREW LENGTH TO SUIT, ALL IN-GROUND FIXINGS TO BE STAINLESS STEEL

DRAWING NO: SRA657512-B
 APPLICATION: SIDE-FIX TO TIMBER RETAINING WALL (POST ON OUTSIDE OF RETAINING WALL)
 LOADING: 0.33kN [F9] AT MAX 2320 POST CENTRES
 LOADING: 0.35kN/m AT MAX 1195 POST CENTRES
 LOADING: 0.75kN/m AT MAX 1195 POST CENTRES
 HEIGHTS: 1500, 1800

IMPORTANT: THIS DESIGN AND ASSOCIATED DESIGN PRODUCER STATEMENTS ARE ONLY RELEVANT FOR PROPRIETARY BOUNDARYLINE PRODUCTS; ANY PRODUCT SUBSTITUTIONS WILL INVALIDATE THE PRODUCER STATEMENT

General Notes

- All dimensions are in millimetres.
- Drawings are not necessarily to scale
- Check www.boundaryline.co.nz to ensure you have the most recent edition of this publication.

Fixing Notes

- All coach screws and bolts to be pre-drilled according to NZS 3603:1993
- When fixing self-drilling screws, ensure low torque setting to avoid thread stripping. A battery drill is recommended for self-drilling screws - DO NOT use an impact driver.

Corrosion Zones

There are four corrosion zones in New Zealand that relate to the severity of exposure to wind-driven salt. See maps in figure 4.2 of NZS 3604:2011 (or online search 'BRANZ Maps') to determine the corrosion zone of the installation location and appropriate fixing option required.

Zone	Risk Level & Location	Fixing Type
Zone B	Low risk	Hot-dip Galvanised
Zone C	Medium risk	Hot-dip Galvanised
Zone D	High risk, all offshore islands, locations within 500m of coastline including harbours, locations within 100m of tidal estuaries and sheltered inlets.	316 Stainless Steel
Zone E	Very high risk, locations described in Zone D, beachfronts and seaside locations.	316 Stainless Steel

Existing Support Structure

- All supporting structure by others and must comply with the New Zealand Building Code
- If unsure of existing structure compliance, seek professional advice.

Boundaryline

Boundaryline Ltd.
 60 Basstian Street, Invercargill
 Phone: 0800 003 006
 Email: enquiries@boundaryline.co.nz
 Website: www.boundaryline.co.nz
 © Copyright June 2025. All rights reserved to Boundaryline Ltd.

This document and the copyright in this document remain the property of BOUNDARYLINE LTD. The contents of this document may not be reproduced either in whole or in part by any means whatsoever without the prior written consent of BOUNDARYLINE LTD.

TITLE
BOUNDARYLINE SENTRY PANEL BARRIER FIXING DESIGNS FOR:
 - CONCRETE IN-GROUND
 - TIMBER RETAINING WALL

FOR 0.33kN, 0.35kN/m & 0.75kN/m LOADING

(REFER TO BARRIER SPECIFICATION GUIDE FOR RELEVANT OCCUPANCY TYPES)

SCALE	SIZE	DRAWING NO
1:15	A4	SEA657501
REV.	DATE ISSUED	SHEET
3	26/05/2026	10

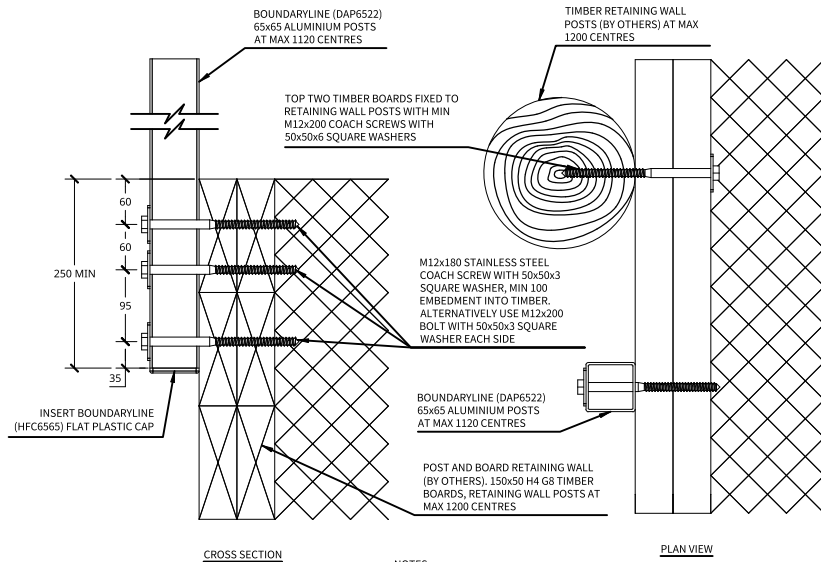

NOTES:
IF WALL IS SLOPING, PACK FENCE POSTS TO VERTICAL AND ADJUST COACH SCREW LENGTH TO SUIT, ALL INGROUND FIXINGS TO BE STAINLESS STEEL

DRAWING NO: SRB657512-B
APPLICATION: SIDE-FIX TO TIMBER RETAINING WALL - DOUBLE BOARD (POST ON OUTSIDE OF RETAINING WALL)
LOADING: 0.33kN [F9] AT MAX 2320 POST CENTRES
LOADING: 0.35kN/m AT MAX 1195 POST CENTRES
LOADING: 0.75kN/m AT MAX 1195 POST CENTRES
HEIGHTS: 1500, 1800

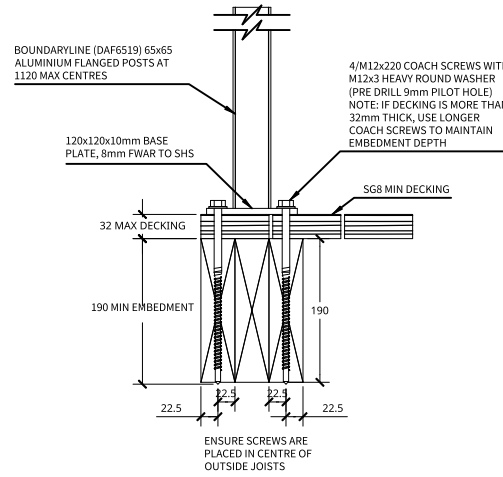

DRAWING NO: TTA657512
APPLICATION: TOP-FIX TO TIMBER DECK
LOADING: 0.33kN [F9] AT MAX 2320 POST CENTRES
LOADING: 0.35kN/m AT MAX 1195 POST CENTRES
LOADING: 0.75kN/m AT MAX 1195 POST CENTRES
HEIGHTS: 1500, 1800

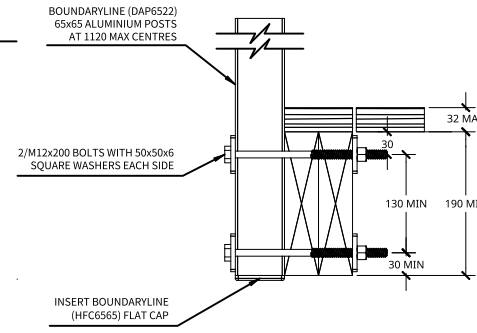

DRAWING NO: STA657512
APPLICATION: SIDE-FIX TO TIMBER DECK
LOADING: 0.33kN [F9] AT MAX 2320 POST CENTRES
LOADING: 0.35kN/m AT MAX 1195 POST CENTRES
LOADING: 0.75kN/m AT MAX 1195 POST CENTRES
HEIGHTS: 1500, 1800

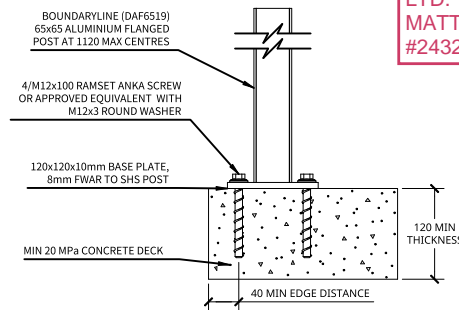

DRAWING NO: TDA657512
APPLICATION: TOP-FIX TO CONCRETE DECK
LOADING: 0.33kN [F9] AT MAX 2320 POST CENTRES
LOADING: 0.35kN/m AT MAX 1195 POST CENTRES
LOADING: 0.75kN/m AT MAX 1195 POST CENTRES
HEIGHTS: 1500, 1800

DATE: 05/06/2026
JOB REF: 25072061-04
REVISION: E
CHECKED & APPROVED BY BREVITY LTD.
MATT BISHOP, CMENGNZ, CPENG
#243276

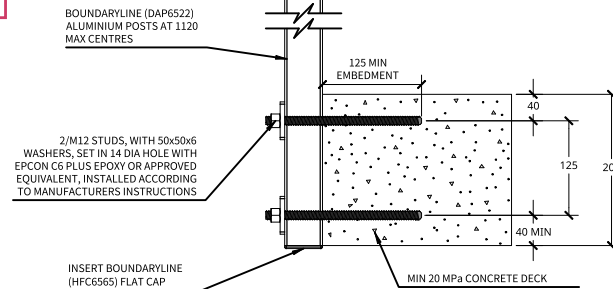

DRAWING NO: SDA657512-A
APPLICATION: SIDE-FIX TO CONCRETE DECK (205 min THICKNESS)
LOADING: 0.33kN [F9] AT MAX 2320 POST CENTRES
LOADING: 0.35kN/m AT MAX 1195 POST CENTRES
LOADING: 0.75kN/m AT MAX 1195 POST CENTRES
HEIGHTS: 1500, 1800

General Notes

- All dimensions are in millimetres.
- Drawings are not necessarily to scale
- Check www.boundaryline.co.nz to ensure you have the most recent edition of this publication.

Fixing Notes

- All coach screws and bolts to be pre-drilled according to NZS 3603:1993
- When fixing self-drilling screws, ensure low torque setting to avoid thread stripping. A battery drill is recommended for self-drilling screws - DO NOT use an impact driver.

Corrosion Zones

There are four corrosion zones in New Zealand that relate to the severity of exposure to wind-driven salt. See maps in figure 4.2 of NZS 3604:2011 (or online search 'BRANZ Maps') to determine the corrosion zone of the installation location and appropriate fixing option required.

Zone	Risk Level & Location	Fixing Type
Zone B	Low risk	Hot-dip Galvanised
Zone C	Medium risk	Hot-dip Galvanised
Zone D	High risk, all offshore islands, locations within 500m of coastline including harbours, locations within 100m of tidal estuaries and sheltered inlets.	316 Stainless Steel
Zone E	Very high risk, locations described in Zone D, beachfronts and seaside locations.	316 Stainless Steel

Existing Support Structure

- All supporting structure by others must comply with the New Zealand Building Code
- If unsure of existing structure compliance, seek professional advice.

Boundaryline

Boundaryline Ltd.
60 Basstian Street, Invercargill
Phone: 0800 003 006
Email: enquiries@boundaryline.co.nz
Website: www.boundaryline.co.nz
© Copyright June 2025. All rights reserved to Boundaryline Ltd.

This document and the copyright in this document remain the property of BOUNDARYLINE LTD. The contents of this document may not be reproduced either in whole or in part by any means whatsoever without the prior written consent of BOUNDARYLINE LTD.

TITLE:
BOUNDARYLINE SENTRY PANEL BARRIER
FIXING DESIGNS FOR:
- TIMBER RETAINING WALL (DOUBLE BOARD)
- TIMBER DECK
- CONCRETE DECK

FOR 0.33kN, 0.35kN/m & 0.75kN/m LOADING

(REFER TO BARRIER SPECIFICATION GUIDE FOR RELEVANT OCCUPANCY TYPES)

SCALE	SIZE	DRAWING NO
1:10	A4	SEA657502
REV.	DATE ISSUED	SHEET
3	26/05/2026	11

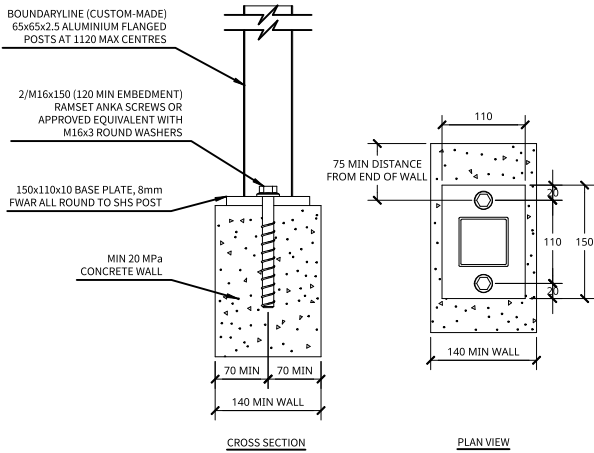

DRAWING NO: TWA657512-A
 APPLICATION: TOP-FIX TO CONCRETE WALL
 LOADING: 0.33kN [F9] AT MAX 2320 POST CENTRES
 LOADING: 0.35kN/m AT MAX 1195 POST CENTRES
 LOADING: 0.75kN/m AT MAX 1195 POST CENTRES
 HEIGHTS: 1500, 1800

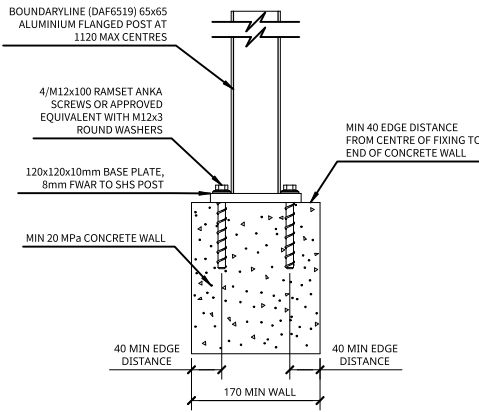

DRAWING NO: TWA657512-B
 APPLICATION: TOP-FIX TO CONCRETE WALL
 LOADING: 0.33kN [F9] AT MAX 2320 POST CENTRES
 LOADING: 0.35kN/m AT MAX 1195 POST CENTRES
 LOADING: 0.75kN/m AT MAX 1195 POST CENTRES
 HEIGHTS: 1500, 1800

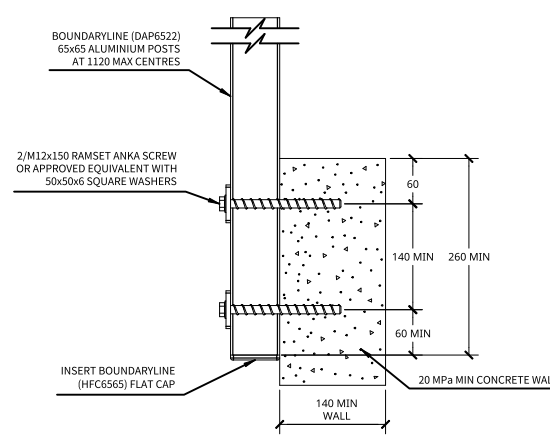

DRAWING NO: SWA657512
 APPLICATION: SIDE-FIX TO CONCRETE WALL
 LOADING: 0.33kN [F9] AT MAX 2320 POST CENTRES
 LOADING: 0.35kN/m AT MAX 1195 POST CENTRES
 LOADING: 0.75kN/m AT MAX 1195 POST CENTRES
 HEIGHTS: 1500, 1800

DATE: 05/06/2026
 JOB REF: 25072061-04
 REVISION: E
 CHECKED & APPROVED BY BREVITY LTD.
 MATT BISHOP, CMENGNZ, CPENG
 #243276

Brevity

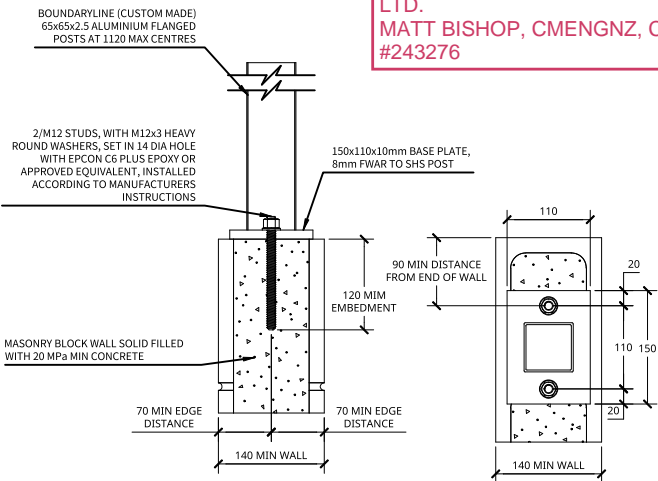

DRAWING NO: TMA657512-A
 APPLICATION: TOP-FIX TO MASONRY WALL (15 SERIES)
 LOADING: 0.33kN [F9] AT MAX 2320 POST CENTRES
 LOADING: 0.35kN/m AT MAX 1195 POST CENTRES
 LOADING: 0.75kN/m AT MAX 1195 POST CENTRES
 HEIGHTS: 1500, 1800

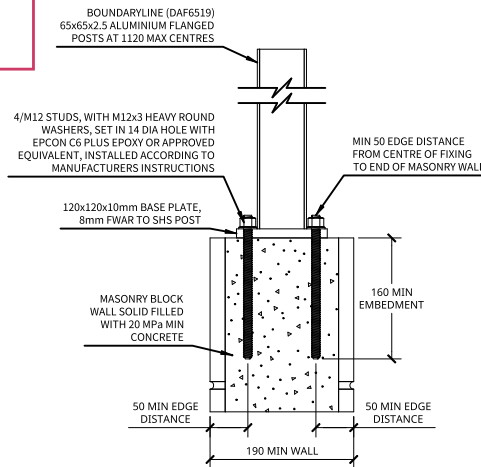

DRAWING NO: TMA657512-B
 APPLICATION: TOP-FIX TO MASONRY WALL (20 SERIES)
 LOADING: 0.33kN [F9] AT MAX 2320 POST CENTRES
 LOADING: 0.35kN/m AT MAX 1195 POST CENTRES
 LOADING: 0.75kN/m AT MAX 1195 POST CENTRES
 HEIGHTS: 1500, 1800

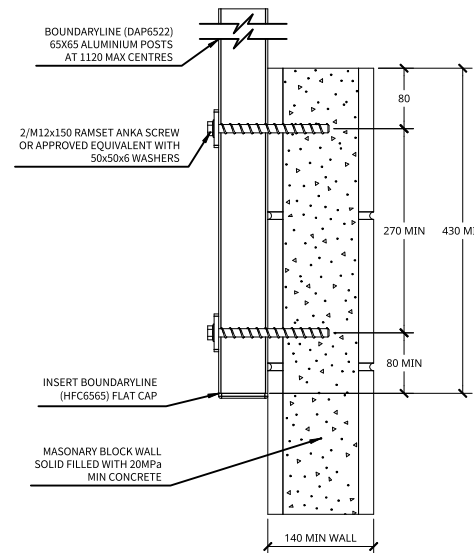

DRAWING NO: SMA657512
 APPLICATION: SIDE-FIX TO MASONRY WALL (15 SERIES)
 LOADING: 0.33kN [F9] AT MAX 2320 POST CENTRES
 LOADING: 0.35kN/m AT MAX 1195 POST CENTRES
 LOADING: 0.75kN/m AT MAX 1195 POST CENTRES
 HEIGHTS: 1500, 1800

- General Notes**
- All dimensions are in millimetres.
 - Drawings are not necessarily to scale
 - Check www.boundaryline.co.nz to ensure you have the most recent edition of this publication.

- Fixing Notes**
- All coach screws and bolts to be pre-drilled according to NZS 3603:1993
 - When fixing self-drilling screws, ensure low torque setting to avoid thread stripping. A battery drill is recommended for self-drilling screws - DO NOT use an impact driver.

Corrosion Zones
 There are four corrosion zones in New Zealand that relate to the severity of exposure to wind-driven salt. See maps in figure 4.2 of NZS 3604:2011 (or online search 'BRANZ Maps') to determine the corrosion zone of the installation location and appropriate fixing option required.

Zone	Risk Level & Location	Fixing Type
Zone B	Low risk	Hot-dip Galvanised
Zone C	Medium risk	Hot-dip Galvanised
Zone D	High risk, all offshore islands, locations within 500m of coastline including harbours, locations within 100m of tidal estuaries and sheltered inlets.	316 Stainless Steel
Zone E	Very high risk, locations described in Zone D, beachfronts and seaside locations.	316 Stainless Steel

- Existing Support Structure**
- All supporting structure by others and must comply with the New Zealand Building Code
 - If unsure of existing structure compliance, seek professional advice.

Boundaryline
 Boundaryline Ltd.
 60 Basstian Street, Invercargill
 Phone: 0800 003 006
 Email: enquiries@boundaryline.co.nz
 Website: www.boundaryline.co.nz
 © Copyright June 2025. All rights reserved to Boundaryline Ltd.

This document and the copyright in this document remain the property of BOUNDARYLINE LTD. The contents of this document may not be reproduced either in whole or in part by any means whatsoever without the prior written consent of BOUNDARYLINE LTD.

TITLE
 BOUNDARYLINE SENTRY PANEL BARRIER
 FIXING DESIGNS FOR:
 - CONCRETE WALL
 - MASONRY WALL

FOR 0.33kN, 0.35kN/m & 0.75kN/m
 LOADING
 (REFER TO BARRIER SPECIFICATION GUIDE FOR RELEVANT OCCUPANCY TYPES)

SCALE	SIZE	DRAWING NO
1:10	A4	SEA657503
REV.	DATE ISSUED	SHEET
3	26/05/2026	12

DATE: 05/06/2026
JOB REF: 25072061-04
REVISION: E
CHECKED & APPROVED BY BREVITY
LTD.
MATT BISHOP, CMENGNZ, CPENG
#243276

Brevity



Auckland

43 Noel Burnside Road
09 250 1144

Christchurch

22 Islington Avenue
03 347 3191

Invercargill

60 Basstian Street
03 211 5145

0800 003 006
boundaryline.co.nz



NZBC Clause B1 Structure - Design

Design Review of Aluminum Balustrades

Project number: 25072061-04E

Client name: Boundaryline Limited

Date: 05/06/2026

Expiry Date: 04/09/2026

Location: Various Locations

Level 9, 4 Williamson Avenue, Ponsonby
Cider Building, Auckland 1021, New Zealand

p: +64 9 216 7104

e: info@teambrevity.com



PRODUCER STATEMENT – PS1 DESIGN

BUILDING CODE CLAUSE(S): B1, F4 & F9 | **JOB NUMBER:** 25072061-04E |

ISSUED BY: Brevity Ltd
(Engineering Design Firm) |

TO: Boundaryline Limited
(Owner/Developer) |

TO BE SUPPLIED TO: -
(Building Consent Authority) |

IN RESPECT OF: Brevity Report # 25072061-04E Design of Boundaryline DuraPanel Sentry Panel |
(Description of Building Work)

AT: Various Location
(Address, Town/City) |

LEGAL DESCRIPTION: Lot no. - DP no. - N/A

We have been engaged by the owner/developer referred to above to provide (Extent of Engagement): Design Consultancy for Structural and Seismic Design of Boundaryline DuraPanel Sentry Panel in respect of the requirements of the Clause(s) of the Building Code specified above for Part only, as specified in the Schedule, of the proposed building work.

The design carried out by us has been prepared in accordance with:

- Compliance documents issued by the Ministry of Business, Innovation & Employment (Verification method/acceptable solution) B1/VM1 - F4/AS1 - F9/AS1 and/or;
- Alternative solution as per the attached Schedule.

The proposed building work covered by this producer statement is described on the drawings specified in the Schedule, together with the specification, and other documents set out in the Schedule.

On behalf of the Engineering Design Firm, and subject to:

- Site verification of the following design assumptions: refer to attached report.
- All proprietary products meeting their performance specification requirements;

I believe on reasonable grounds that:

- the building, if constructed in accordance with the drawings, specifications, and other documents provided or listed in the Schedule, will comply with the relevant provisions of the Building Code and that;
- the persons who have undertaken the design have the necessary competency to do so.

I recommend the CM 1 level of construction monitoring.

I, (Name of Engineering Design Professional) Matt Bishop, am:

- CPEng number 243276 and hold the following qualifications BE (Hons)

The Engineering Design Firm holds a current policy of Professional Indemnity Insurance no less than \$200,000
The Engineering Design Firm is a member of ACE New Zealand.

SIGNED BY (Name of Engineering Design Professional): Matt Bishop
(Signature below):

Issue Date 05/06/2026

ON BEHALF OF (Engineering Design Firm): Brevity Ltd

Expiry Date: 04/09/2026

Note: This statement has been prepared solely for the Building Consent Authority named above and shall not be relied upon by any other person or entity. Any liability in relation to this statement accrues to the Engineering Design Firm only. As a condition of reliance on this statement, the Building Consent Authority accepts that the total maximum amount of liability of any kind arising from this statement and all other statements provided to the Building Consent Authority in relation to this building work, whether in tort or otherwise, is limited to the sum of \$200,000.

This form is to accompany **Form 2 of the Building (Forms) Regulations 2004** for the application of a Building Consent.

Contents

Document Revision History	2
1. Overview	3
2. Design Methodology and Loading	4
3. Construction Monitoring	4
4. Our Contact Details	6

Document Revision History

Rev	Date	Revision details	Author	Approved
A	27/08/2025	For Consent	CE	MB
B	02/09/2025	Updated Document	RK	MB
C	04/09/2025	Updated Company Name	CE	MB
D	28/05/2026	Updated Document (Playground Panel & CM Schedule)	RK	MB
E	05/06/2026	Updated Drawings	TA	MB

1. Overview

Brevity has been engaged by Boundaryline to provide a Chartered Engineer's PS1 – Design Review for the Aluminum Balustrades for Global Design, for various locations in New Zealand. This report summarizes the engineering design criteria and records, key decisions, and outcomes as per NZ standards.

All information, details, or designs portrayed in this document remain the copyright of Brevity Ltd (Brevity), unless Brevity has expressly agreed otherwise with the client. Any reproduction without the express permission of Brevity is prohibited.

This report has been prepared by Brevity on the specific instructions of our client. It is solely for our client's use for the purpose for which it is intended in accordance with the agreed scope of work. Any use or reliance by any person contrary to the above, to which Brevity has not given its prior written consent, is at that person's risk.

2. Design Methodology and Loading

In accordance with the New Zealand Building Code Section B1 by Specific Engineering Design to B1, F4, and F9 by specific engineering design to VM1 and AS1 the engineering system was checked to the following loading standards:

- AS/NZS 1170 Series
- NZS 3404: Part 1:1997
- AS/NZS 1664.1 :1997
- AS/NZS 1720.1:2022.

Based on the previous project for this type of structure, wind is the key factor influencing the design.

3. Construction Monitoring

Construction monitoring is to be carried out before finishes are installed (e.g. linings or tiles).

The following table outlines guidance for the required elements to be inspected for issuance of a Producer Statement - PS4 - Construction Review:

Element	Random Sampling	Stage	Person
Structure: <ul style="list-style-type: none">- Posts or spigots- Infill- Handrails- Anchors	100% Visual Scan ¹ 5% Visual Inspection ² Compare to Brevity plans	Structure Complete Before spigot covers or other items that obstruct viewing of the anchors are installed	Site Engineer

¹Where Visual Scan is required, floor level access is to be supplied by the client.

²Where Visual Inspection is required, access is to be supplied by the client to allow measurement of specific details.

We recommend CM1 level of construction monitoring for this project. Please see the following page for a description of the various levels.

CM1 Review

Monitor the outputs from another party's quality assurance programme against the requirements of the plans and specifications. Visit the works at a frequency agreed with the client to review important materials of construction critical work procedures and/or completed plant or components. Be available to advise the constructor on the technical interpretation of the plans and specifications

This level is only a secondary service. It may be appropriate where:

- For the design consultant when another party is engaged to provide a higher level of construction monitoring or review during the period of construction or
- When the project works are the subject of a performance based specification and performance testing is undertaken and monitored by others.

CM2 Review

Review, preferably at the earliest opportunity, a sample of each important work procedure, material of construction and component for compliance with the requirements of the plans and specifications and review a representative sample of each important completed work prior to enclosure or completion as appropriate. Be available to provide the constructor with technical interpretation of the plans and specifications.

This level of service is appropriate for smaller projects of a routine nature being undertaken by an experienced and competent constructor and where a higher than normal risk of non-compliance is acceptable. It provides for the review of a representative sample of work procedures and materials of construction. The assurance of compliance of the finished work is dependent upon the constructor completing the work to at least the same standard as the representative sample reviewed.

CM3 Review

Review, to an extent agreed with the client, random samples of important work procedures, for compliance with the requirements of the plans and specifications and review important completed work prior to enclosure or on completion as appropriate. Be available to provide the constructor with technical interpretation of the plans and specifications.

This level of service is appropriate for medium sized projects of a routine nature being undertaken by an experienced constructor when a normal risk of non-compliance is acceptable.

CM4 Review

Review, at a frequency agreed with the client, regular samples of the work procedures, materials of construction and components for compliance with the requirements of the plans and specifications and review the majority of completed work prior to the enclosure or on completion as appropriate.

This level of service is appropriate for projects where a lower than normal risk of non-compliance is required.

CM5 Review

Maintain personnel on site to constantly review work procedures, materials of construction and components for compliance with the requirements of the plans and specifications and review completed work prior to enclosure or on completion as appropriate.

This level of service is appropriate for: Major projects, Projects where the consequences of failure are critical, Projects involving innovative or complex construction procedures. The level of service provides the client with the greatest assurance that the completed work complies with the requirements of the plans and specifications.

4. Our Contact Details

Engineer's contact details for this report

Contact	Contact details
This report was prepared by	Terence Abdon
Email	engineering@teambrevity.com

Auckland office

Contact	Contact details
Main office phone	+64 9 216 7104
Email for all enquiries	info@teambrevity.com
Mailing address	Cider Building Level 9, 4 Williamson Ave Ponsonby, Auckland 1021 New Zealand